



TECNOCAT FACTORY SERIES

VNL-GB2 | VNL-GB2+2

VNL-GB2 | VNL-GB2+2



FACTORY SERIES

VNL-GB2 COMPATIBLE WITH: CML-B4

	200 kg
	52 kg

FACTORY SERIES



- * HOIST NOT REQUIRED
- * ELEVATION BY MEANS OF PNEUMATIC PISTON

AIR	7 bar 200 l/min
	0° - 90°
	—

	40 L/min
	0° - 90°

VNL-GB2

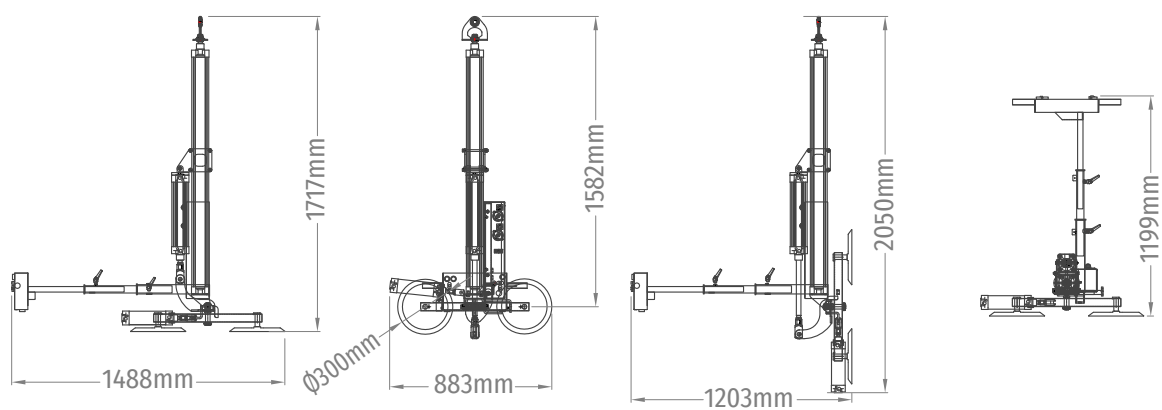

VNL-GB2+2

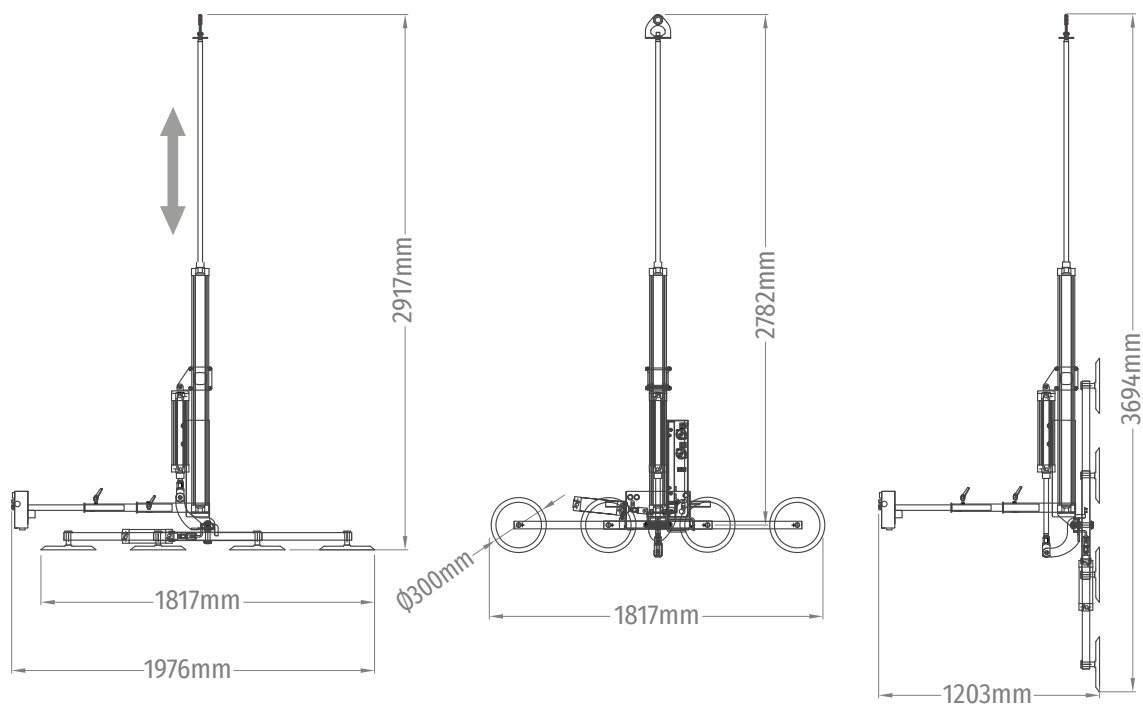

PICTOGRAMS



ELECTRICAL POWER



NOMINAL ELECTRIC POWER



ENERGY AUTONOMY BY BATTERIES



PNEUMATIC SUPPLY



MAXIMUM LOAD CAPACITY



MAXIMUM LOAD CAPACITY ACCORDING EN-13155



TILTING EQUIPMENT



MANUALLY TILTING EQUIPMENT



PNEUMATIC TILTING EQUIPMENT



MOTORIZED TILTING EQUIPMENT



HYDRAULIC TILTING EQUIPMENT



ROTATION EQUIPMENT



MANUAL ROTATION EQUIPMENT



PNEUMATIC ROTATION EQUIPMENT



MOTORIZED ROTATION EQUIPMENT



HYDRAULIC ROTATION EQUIPMENT



EQUIPMENT WEIGHT



VACUUM SYSTEM AIR FLOW



PUSHBUTTON CABLE LENGTH



WIRELESS PUSHBUTTON



LOAD CAPACITY ACCORDING EN-13155



EQUIPMENT SUPPORT SYSTEM



LIFTING CRANE USABLE ROTATION

PICTOGRAMS



TECNOCAT 21, S.L. Av. del Coure 4, Pol.Ind. Argenteria 43470 - La Selva del Camp (Tarragona) SPAIN
+34 977 76 61 97 | info@tecnocat.com www.tecnocat.com